

Model WS100 with analog output

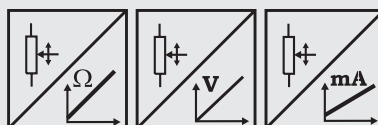

Sensor for hostile environments and offshore applications, with compression-proof sealing

- Protection class IP68
- Measurement ranges:
0 ... 2000 mm und 0 ... 3500 mm
- Analog output
- Anodized aluminium housing



Specifications	Outputs	Potentiometer: 1 kΩ Voltage: 0...10 V Current: 4...20 mA, 2 or 3 wire
	Material	Stainless steel or aluminium; cable: stainless steel
Resolution	Essentially infinite	
Sensing device	Hybrid precision potentiometer	
Connection	Cable output, standard length 1.5 m	
Linearity	Up to ±0.05 % full scale	
Weight	Approx. 13 kg (stainless steel)	
Temperature range	-20 to +70 °C	
Conformity to standards		
EMC	EN 61326:2004	
Protection class of housing	EN 60529:2000, IP 67	
Shock	EN 60068-2-27:1993, 50 g 11 ms, 100 shocks	
Vibration	EN 60068-2-6:1995, 20 g, 10 Hz...2 kHz, 10 cycles	

Order code WS100 Analog

Model name

WS100AL = Version in aluminium housing

Measurement Range (in mm)

2000 / 3500

Outputs (see pages 57 and 58)

R1K = potentiometer 1 kΩ (other values on request)

10V = with 0 ... 10 V signal conditioner

420A = mit 4 ... 20 mA signal conditioner (2 wire)

420T = mit 4 ... 20 mA signal conditioner (3 wire)

Other outputs on request

Linearity

L10 = ±0.10 % option: L05 = ±0,05 % L25 = ±0.25 %

Connection

KAB1,5M = cable output, length 1.5 m (standard)

Cable fixing

M4 = M4 cable fixing

SB0 = Cable clip

WS100xxx - [] - [] - [] - [] - []

Order Example: WS100AL - 2000 - 420A - L10 - KAB1,5M - M4

Model WS100 with analog output



Cable forces typical at 20 °C	Range	Maximum pull-out force	Minimum pull-in force
	[mm]	[N]	[N]
	2000	5.2	2.8
	3500	6.2	3.0

Outline drawing
WS100 - 2000

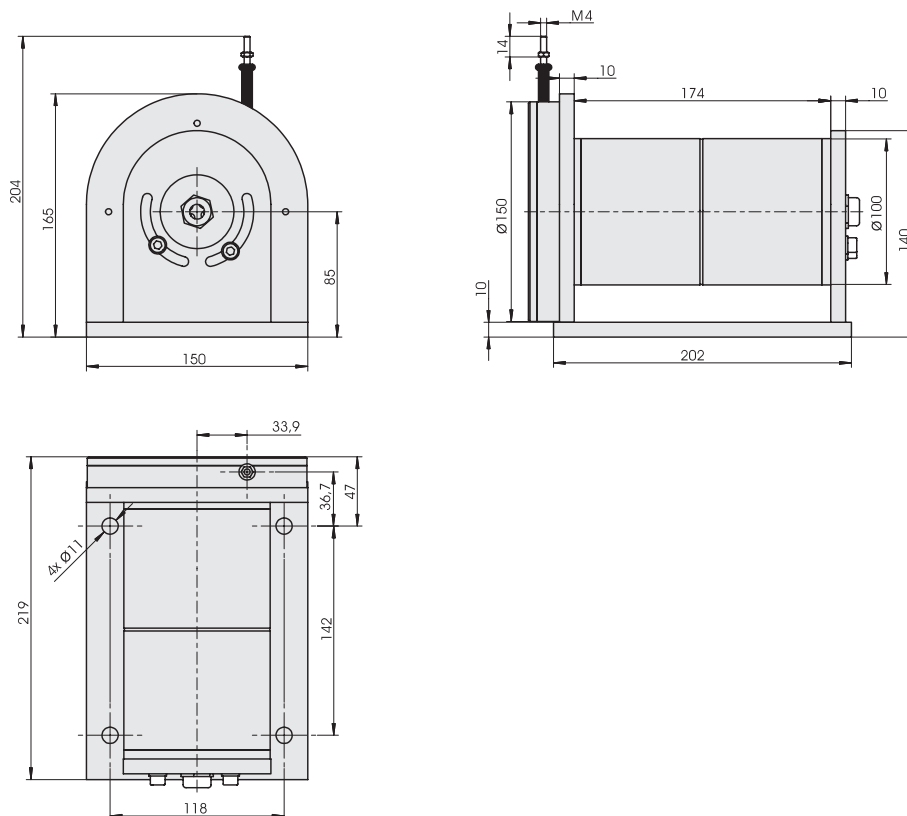

Outline drawing
WS100 - 3500

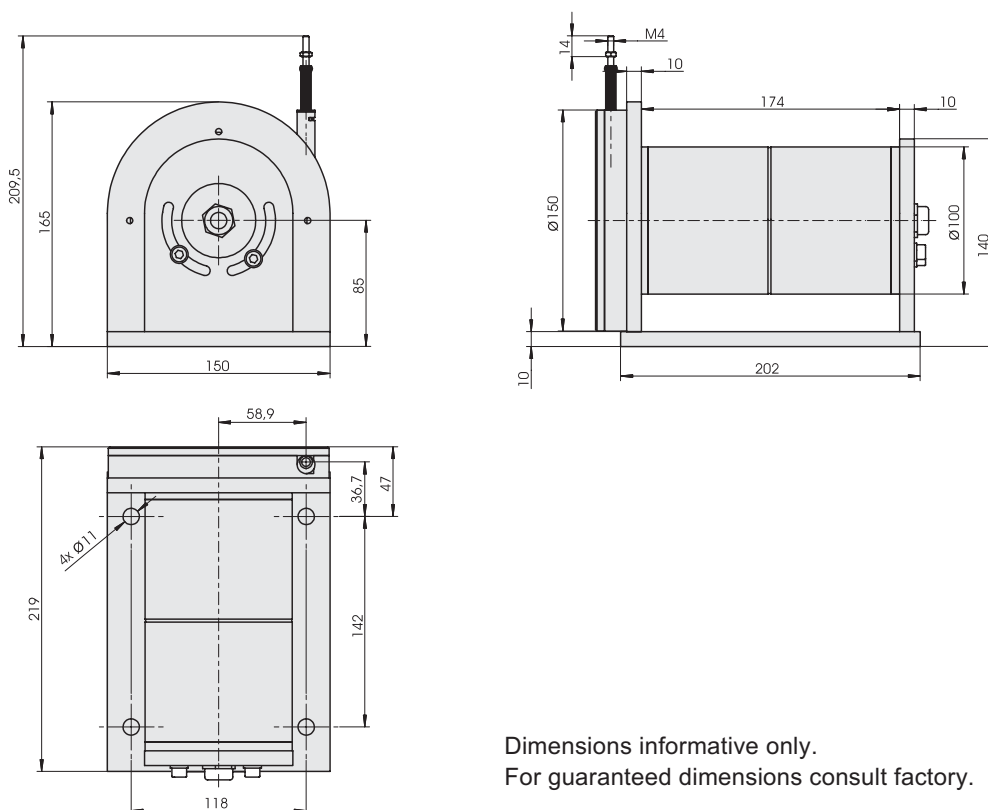

Dimensions informative only.
For guaranteed dimensions consult factory.

Model WS100 with incremental encoder output



Sensor for hostile environments and offshore applications, with compression-proof sealing

- Protection class IP68
- Measurement ranges:
0 ... 2000 mm and 0 ... 3500 mm
- With incremental encoder output
- Anodized aluminium housing



Specifications		
Outputs	Incremental encoder output HTL or TTL compatible	
Material	Stainless steel or aluminium; cable: stainless steel	
Resolution	2000 mm: 5 or 10 pulses per mm 3500 mm: 2.75 or 5.5 pulses per mm	
Sensing device	Incremental encoder	
Connection	Cable output, standard length 1.5 m	
Linearity	Up to $\pm 0.05\%$ full scale	
Weight	Approx. 13 kg (stainless steel)	
Temperature	-20 to +70 °C	
Conformity to standards		
EMC	EN 61326:2004	
Protection class of housing	DIN EN 60529:2000, IP 67	
Shock	DIN EN 60068-2-27:1993, 50 g 11 ms, 100 shocks	
Vibration	DIN EN 60068-2-6:1995, 20 g, 10 Hz ... 2 kHz, 10 cycles	

Order code WS100 Incremental

Model name

WS100AL = Version in aluminium housing

Measurement Range (in mm)

2000 / 3500

Pulses per mm

2000 mm: 5 / 10
3500 mm: 2.75 / 5.5

Outputs (see page 60)

IE24LI = Incremental encoder TTL compatible inverted
IE24HI = Incremental encoder HTL compatible inverted

Connection

KAB1,5M = Cable output, length 1.5 m (standard)

Cable fixing

M4 = M4 cable fixing
SB0 = Cable clip

WS100xxx - [] - [] - [] - [] - []

Order Example: WS100AL - 2000 - 10 - IE24HI - KAB1,5M - M4

Model WS100 with incremental encoder output



Cable forces typical at 20 °C	Range	Maximum pull-out force	Minimum pull-in force
	[mm]	[N]	[N]
	2000	5.2	2.8
	3500	6.2	3

Outline drawing
WS100 - 2000

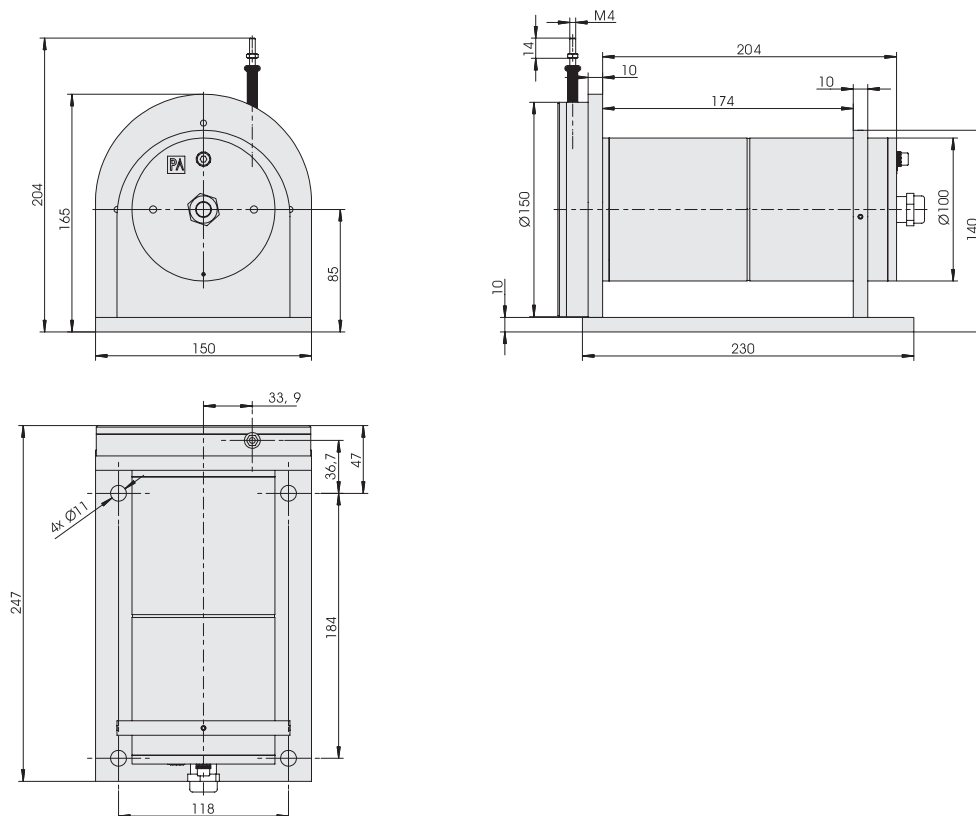

Outline drawing
WS100 - 3500

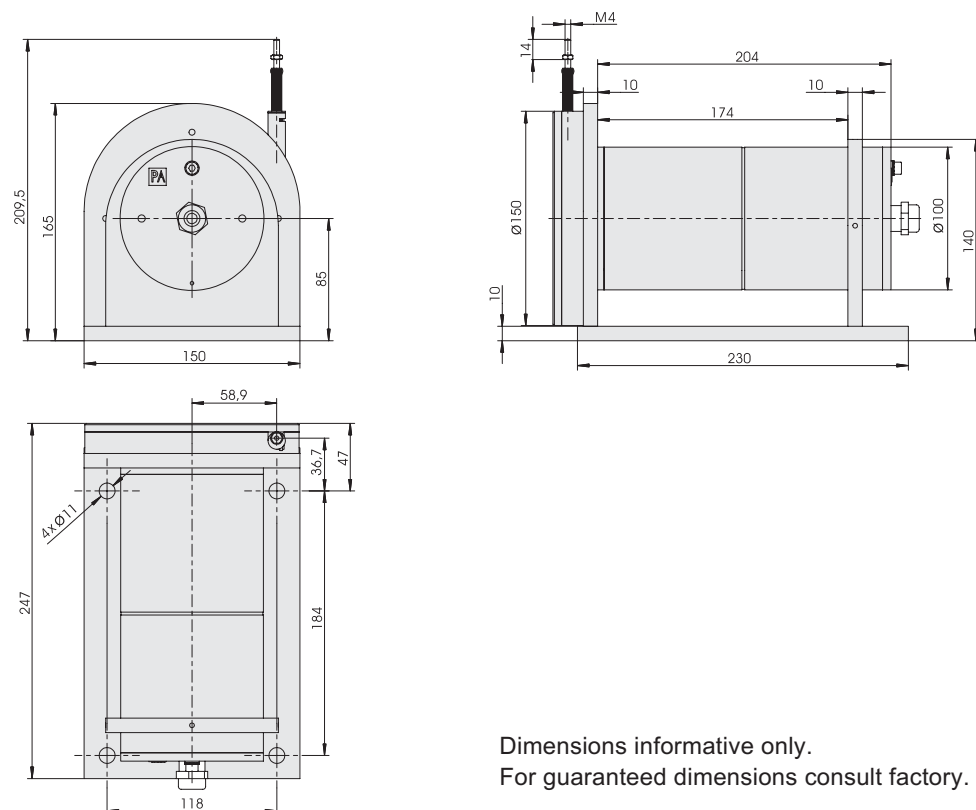

Dimensions informative only.
For guaranteed dimensions consult factory.

Output Specifications

R1K and 10V for WS position sensors



Voltage divider R1K Potentiometer 	Excitation Voltage	32 VDC max. at 1 k Ω (input power 1 W max.)
	Potentiometer Impedance	1 k Ω \pm 10%
	Thermal coefficient	\pm 25 x 10 ⁻⁶ / °C full scale
	Sensitivity	Depends on measurement range, individual sensitivity of sensor specified on label
	Voltage Divider Utilization Range	Approx. 3% ... 97% of full range
	Operating Temperature	-20 ... +85 °C

Signal diagram

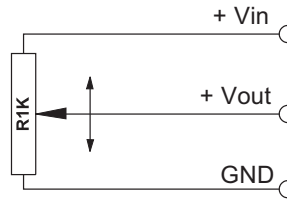

Note: The potentiometer must be connected as a voltage divider. The input impedance of the following processing circuit should be 10 M Ω min.

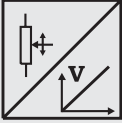
Signal conditioner 10V Voltage output 	Excitation Voltage	+18 ... +27 V DC non stabilized
	Excitation Current	20 mA max.
	Output Voltage	0 ... +10 V DC
	Output Current	2 mA max.
	Output Load	> 5 k Ω
	Stability (Temperature)	\pm 50 x 10 ⁻⁶ / °C full scale
	Protection	Reverse polarity, short circuit
	Output Noise	0,5 mV _{RMS}
	Operating Temperature	-20 ... +85 °C
	EMC	According to EN 61326:2004

Signal diagram

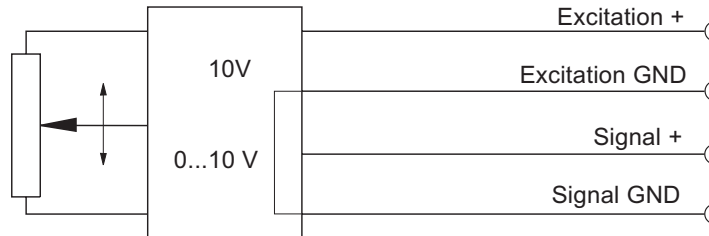

Signal Wiring	Output signals		Cable color	Connector pin no.
	R1K	10V		
	+ Vin	Excitation +	White	1
	GND	Excitation GND	Brown	2
	+ Vout	Signal +	Green	3
		Signal GND	Yellow	4

Connection

Mating Connector

View to solder terminals

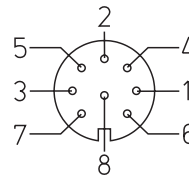

CONN-DIN-8F-W

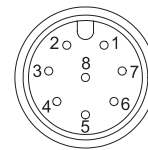

CONN-M12-8F-G

Output Specifications

420A and 420T for WS position sensors

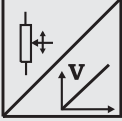

Signal conditioner 420A Current output (2 wire) 	Excitation Voltage	+12 ... 27 VDC non stabilized, measured at the sensor terminals
	Excitation Current	35 mA max.
	Output Current	4 ... 20 mA equivalent to 0 ... 100% range
	Stability (Temperature)	$\pm 100 \times 10^{-6} / ^\circ\text{C}$ full scale
	Protection	Reverse polarity, short circuit
	Output Noise	0.5 mV _{RMS}
	Operating Temperature	-20 ... +85 °C
	EMC	According to EN 61326:2004

Signal Diagram

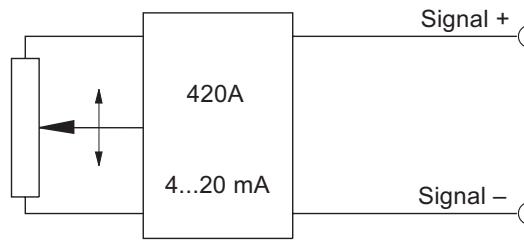

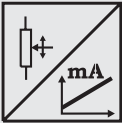
Signal Conditioner 420T Current output (3 wire) 	Excitation Voltage	+18...+27 V DC non stabilized
	Excitation Current	40 mA max.
	Load Resistor	350 Ω max.
	Output Current	4 ... 20 mA equivalent to 0 ... 100% range
	Stability (Temperature)	$\pm 50 \times 10^{-6} / ^\circ\text{C}$ full scale
	Protection	Reverse polarity, short circuit
	Output Noise	0.5 mV _{RMS}
	Operating Temperature	-20 ... +85 °C
	EMC	According to EN 61326:2004

Signal diagram

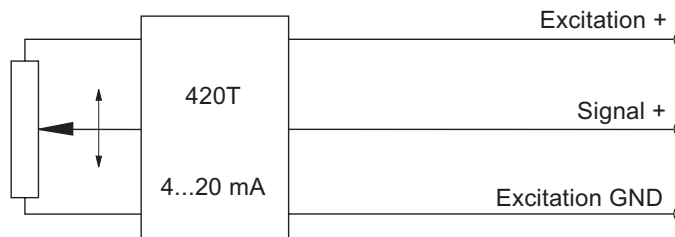

Signal Wiring	Output signals		Cable color	Connector pin no.
	420A	420T		
	Signal +	Excitation +	White	1
	Signal -	Excitation GND	Brown	2
		Signal +	Green	3

Connection

Mating Connector

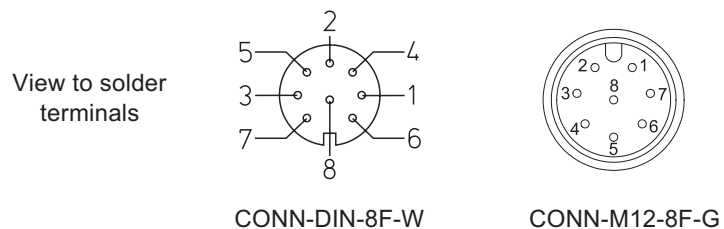

Output Specifications

IE24LI and IE24HI for WS position sensors



IE24LI and IE24HI incremental	IE24LI		IE24HI
	Excitation voltage	5 V DC $\pm 10\%$	
Excitation current	100 mA max.		
Output frequency	200 kHz		
Output	Push-pull and inverted signals		
Output current	10 mA max.		
Output voltage	Depending on the excitation voltage		
Stability (temperature)	$\pm 20 \times 10^{-6} / ^\circ\text{C}$ f.s. (sensor mechanism)		
Operation temperature	-20 ... +85 $^\circ\text{C}$		
Protection	Short circuit		
EMC	According to EN 61326:2004		



Output signals

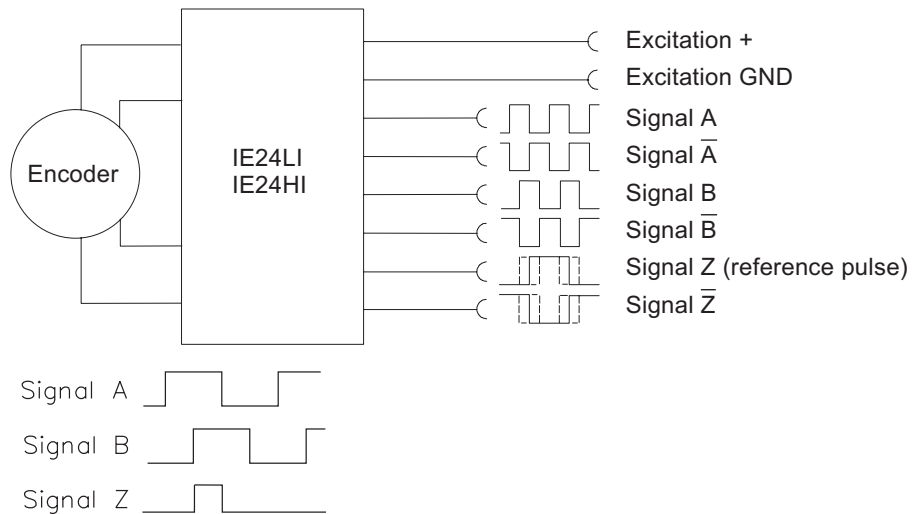

Output circuit and recommended processing input circuit

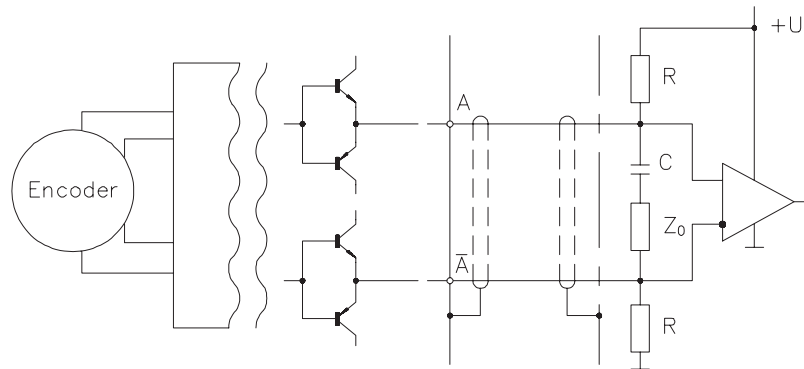

Signal wiring	Output signals	Cable color	Connector pin no.
	Excitation +	Brown	1
	Excitation GND	White	2
	Signal B (A + 90°)	Grey	3
	Signal A	Green	4
	Signal B-bar	Pink	5
	Signal A-bar	Yellow	6
	Signal Z (reference pulse)	Blue	7
	Signal Z-bar	Red	8

Connection

Mating connector

