

### Wide-Bandwidth and High-Precision Current Measurement

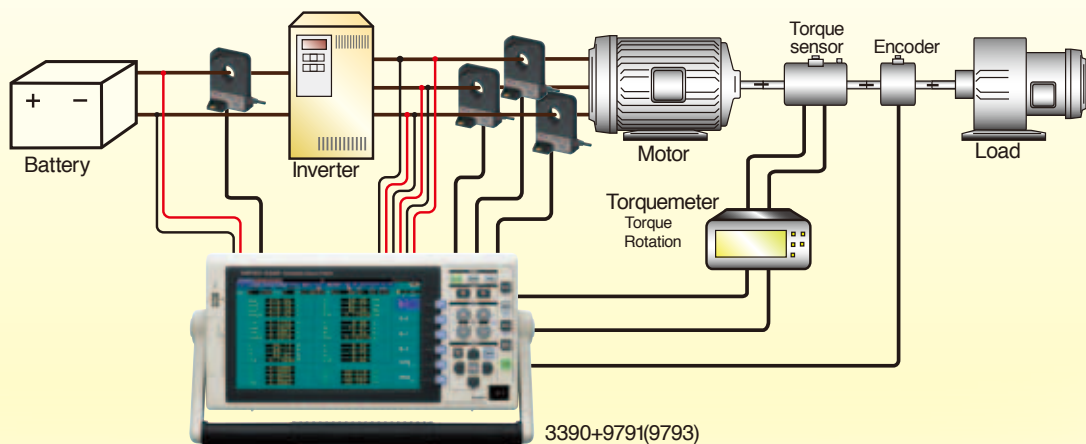

HIOKI 9709, CT6862, and CT6863 wide-bandwidth and high-precision AC/DC current sensors achieve high accuracy measurement of both small- and large-current signals. They can be used for a wide variety of applications in the fields of electric and hybrid electric vehicles, inverters and other devices, alternative energy sources such as solar power and fuel cells, as well as home electronic appliances and system equipment.

Ideal for comprehensive evaluation of wide-bandwidth and high-precision inverter motors



# HIOKI's Current Sensors Support More Accurate Current and Power Measurements

## ■When a current sensor is used:

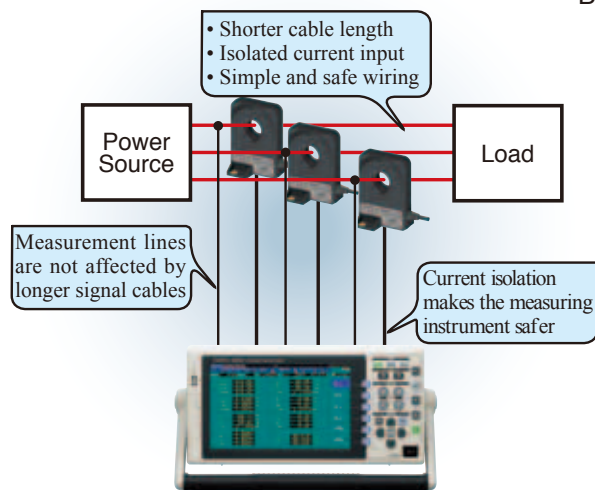

## New Age for Current Measurement with High Precision, Wide Bandwidth, and Excellent Temperature Characteristics

- Achieve a maximum accuracy of  $\pm 0.16\%$ , which is equivalent to power meters using a direct cable connection (when used with the POWER ANALYZER 3390).
- The cable connecting the power source and load can be made thicker and shorter to allow measurement to be performed in nearly the same cable condition as the real operation of a device under test.
- Insert loss is far smaller than with a shunt resistor so the operation of a device under test is not affected.
- A wide range of measurements are possible, including battery charge and discharge measurement and inverter secondary circuit measurement.
- A wide operating temperature range allows the sensor to be used in the same environment conditions as a device under test.
- Installing a power line is simple, secure, and safe.
- Excellent characteristics reduce the effect of the conductor position, external magnetic field, and magnetization
- CAT III 1000V Safe
- Convenient voltage output design

## ■Specifications

	CT6862	CT6863	9709
Frequency characteristics	DC to 1 MHz	DC to 500 kHz	DC to 100 kHz
Rated current	50 A AC/DC	200 A AC/DC	500 A AC/DC
Output voltage	2 V/50 A	2 V/200 A	2 V/500 A
Measurable conductor diameter	26 mm(1.02") or less		36 mm(1.42") or less
Compatible power meters	3193(with 9602), 3194 (with 9602), 3390, PW6001		
Output resistance	50 $\Omega$		
Basic accuracy	DC, $16\text{ Hz} \leq f \leq 400\text{ Hz}$ $\pm 0.05\%$ rdg. $\pm 0.01\%$ f.s. $\pm 0.2\text{ deg}$ Accuracy is given for 0°C to 40°C, 80% rh or less		DC, $45\text{ Hz} \leq f \leq 66\text{ Hz}$ $\pm 0.05\%$ rdg. $\pm 0.01\%$ f.s. $\pm 0.2\text{ deg}$ Accuracy is given for 18°C to 28°C, up to 80% rh
Period of accuracy guaranteed	Accuracy guaranteed for 1 year, Post-adjustment accuracy guaranteed for 1 year		Accuracy guaranteed for 6 months, Post-adjustment accuracy guaranteed for 6 months
Max. rated voltage to earth	AC/DC 1000 V (50/60 Hz) (measurement category III)		
Cord length	3 m (9.84 ft)		
Operating temperature and humidity range	-30°C to 85°C, 80% RH or less (with no condensation)		0°C to 50°C, 80% RH or less (with no condensation)
Dimensions, Mass	70W (2.76") $\times$ 100H (3.94") $\times$ 53D (2.09") mm, 340 g (12.0 oz)	160W (6.30") $\times$ 112H (4.41") $\times$ 50D (1.97") mm, 850 g (30.0 oz)	
Supplied Accessories	Instruction manual $\times$ 1, Mark bands $\times$ 6		

**Options**

**SENSOR UNIT 9555-10**  
Power supply for current sensors when used alone

**CONNECTION CORD L9217**  
Cord has insulated BNC connectors at both ends, for signal output, 1.6 m (5.25 ft) length

**CONNECTION CORD 9165**  
Cord has metallic BNC connectors at both ends, use at metallic terminal, 1.5 m (4.92 ft) length, not CE marked

**CONVERSION CABLE 9318**  
To connect the CT6841/43, CT6865/63, 9277/78/79, 9270/71/72 to the 8971/40/51, 38 cm (14.96 in) length

**CONVERSION CABLE CT9900**  
For current sensor connector 10 pins to 12 pins

\*CT9900 for connecting to the PW6001

**Options**

Both the 9318 and 9705 are required in order to connect to the F/V Unit 8940

**CONVERSION CABLE 9705**  
0.2 m (0.66 ft) length, to connect the CT6841/6843, CT6863/6865, 9709, 9272-10 to the F/V Unit 8940  
Cannot be used in combination with the CT6862

**EXTENSION CABLE 9706**  
Extension for 5 m (16.41 ft) length, connect up to 2 cables in series.  
Caution! Cannot be used in combination with the CT6862/63 or 9277 to 9279

## ■Mounting diagram (unit : mm)

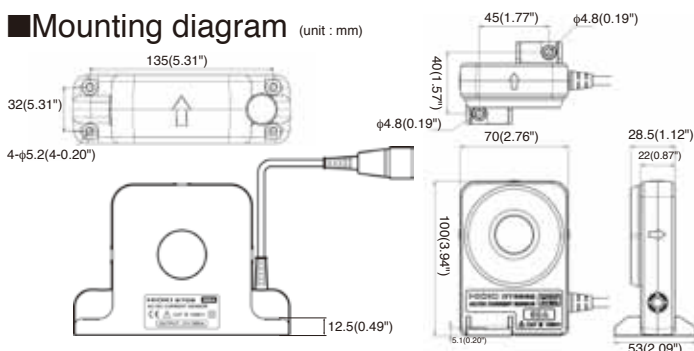

## Model : AC/DC CURRENT SENSOR

Model No. (Order Code)	(Note)
CT6862	(50 A AC/DC)
CT6862-05	(50 A AC/DC, 12 pin terminal)
CT6863	(200 A AC/DC)
CT6863-05	(200 A AC/DC, 12 pin terminal)
9709	(500A AC/DC)
9709-05	(500 A AC/DC, 12 pin terminal)

Note: Company names and Product names appearing in this catalog are trademarks or registered trademarks of various companies.

**HIOKI**  
HIOKI E. E. CORPORATION

HEADQUARTERS  
81 Koizumi, Ueda, Nagano, 386-1192, Japan  
TEL +81-268-28-0562 FAX +81-268-28-0568  
http://www.hioki.com / E-mail: os-com@hioki.co.jp

DISTRIBUTED BY



ASM Automation Sensorik Messtechnik GmbH

Tel. +49 8123 986-0  
info@asm-sensor.de  
www.asm-sensor.de

Am Bleichbach 18 - 24  
85452 Moosinning