

  **WBT85**

Combined displacement and inclination sensor with measurement ranges up to 6,000 mm / $\pm 180^\circ$



- Protection class up to IP67/IP69
- Robust stainless steel measurement tape
- Multiple deflections possible
- With magnetic absolute encoder
- With inclination sensor in MEMS technology
- Redundant version available

Product version



Digital output CANopen

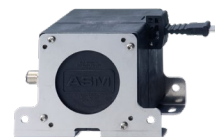

WBT85 - Combined displacement and inclination sensor
Version with digital output CANopen

Specifications

		Order options
Measurement range (position)	5000 / 6000mm	1 5000 / 6000
Measurement range (inclination)	±180° with 1 axis	
Inclination axis	Inclination in X axis ≤±180°	
Resolution	setting via CAN-Bus	
Output	Digital output CANopen Digital output CANopen, redundant	2 MCANOP MCANOPR
Linearity of position measurement	±0.10% f.s. (standard) ±0.05% f.s. (optional)	3 L10 L05
Linearity of inclination measurement	0.05° (±30°) 0.1° (±60°) 0.2° (±180°)	
Sensing device (position measurement)	Magnetic absolute encoder	
Sensing device (inclination measurement)	MEMS device	
Material	PBT, stainless steel Tape: stainless steel, 10 mm wide, 0,08 mm thick	
Protection class	IP67/IP69	
Connection	Connector M12, 5 pin	4 M12/CAN
Dust wiper		5 BAB1
Shock	DIN EN 60068-2-27:1993, 100 g/11 ms, 100 shocks	
Vibration	DIN EN 60068-2-6:2008, 20 g 10 Hz-2 kHz, 10 cycles	
Temperature range	-40 ... +85°C	
Weight	approx. 1000 g with mountig brackets (250 g)	
EMC	DIN EN 61326-1:2013	

Order code

WBT85 – **1** – **2** – **3** – **4** – **5**

Order example: WBT85 – 6000 – MCANOP – L10 – M12/CAN – BAB1

Dimensions

WBT85

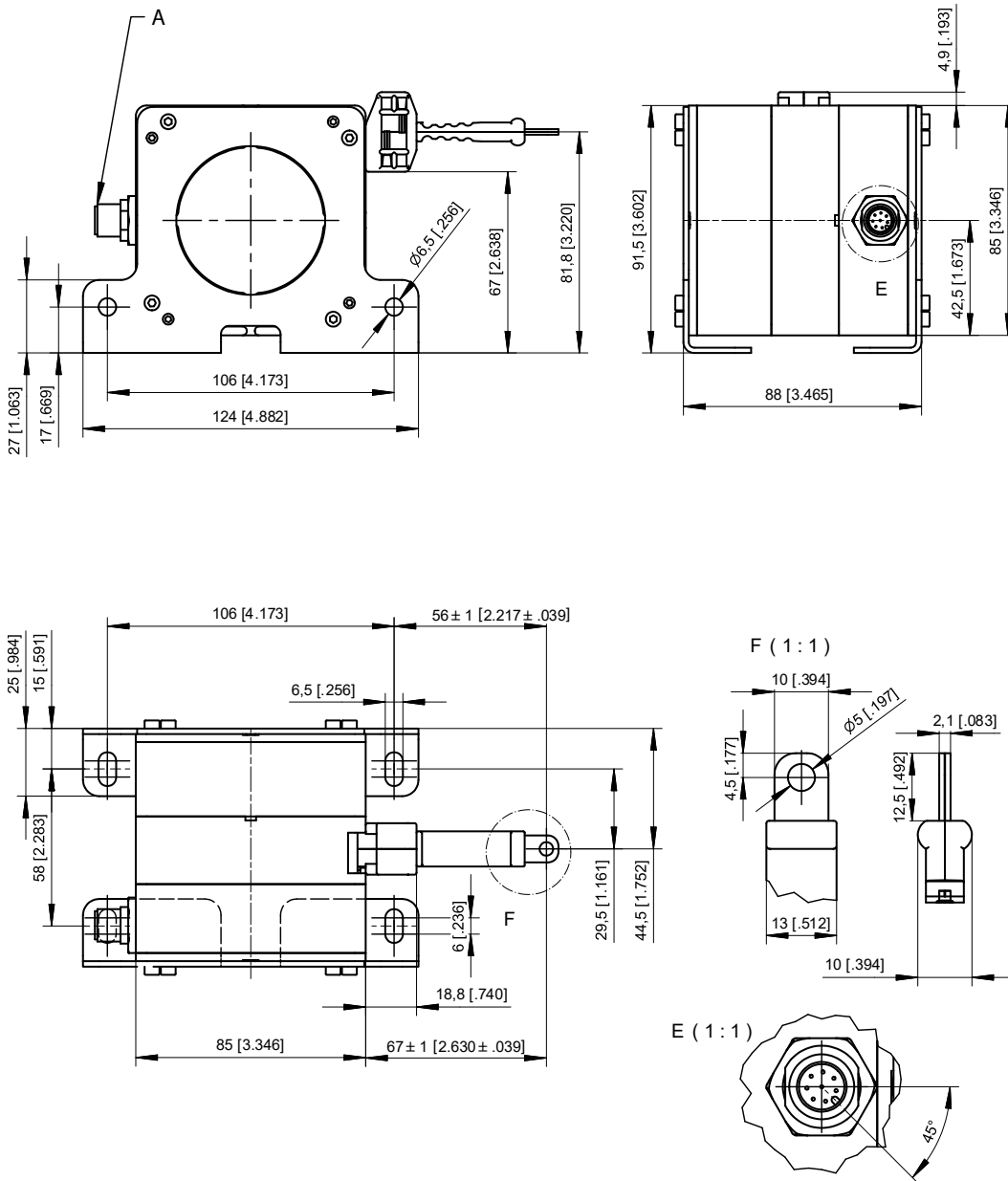

A – Connector M12

Dimensions in mm [inch]

Dimensions informative only.

For guaranteed dimensions consult factory.

Mounting options for inclination measurement for WBT61 / WBT85 sensors

The mounting option can be set by the user via software. Sensor position as shown equals 0°.

WBT61 / WBT85

Mounting option 1

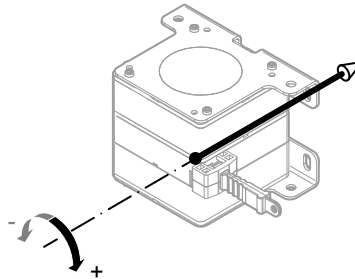

Mounting option 2

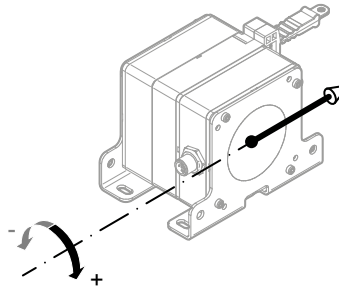

Mounting option 3

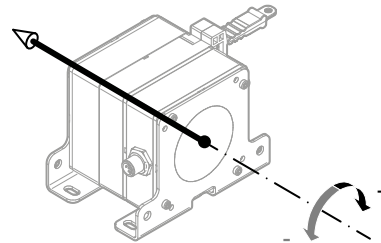

Output signal

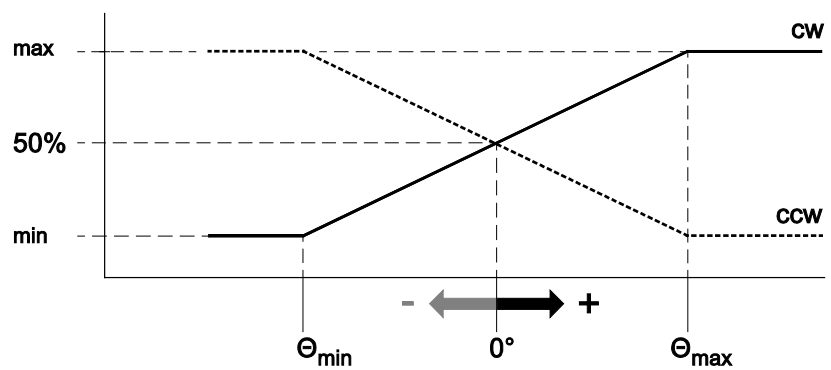

Interface CANopen

MCANOP, CANOPR		
	CAN specification	ISO 11898, Basic and Full CAN 2.0 B
	Communication profile	CANopen CiA 301 V 4.02, Slave
	Encoder profile	Encoder CiA 406 V 3.2
	Error Control	Node Guarding, Heartbeat, Emergency Message
	Node ID	Adjustable via LSS or SDO, default: 127
	PDO	3 TxPDO, 0 RxPDO, no linking, static mapping
	PDO Modes	Event-/Time triggered, Remote-request, Sync cyclic/acyclic
	SDO	1 Server, 0 Client
	CAM	8 cams
	Certified	Yes
	Transmission rate	50 kBit bis 1 Mbit, adjustable via LSS or SDO, default: 125 kBit
	Bus connection	M12 connector, 5 pin
	Integrated bus terminating resistor	120Ω adjustable by the customer
	Bus, galvanic isolated	no

Specifications	
Excitation voltage	8 ... 36 V DC
Excitation current	20 mA typical at 24 V DC 40 mA typical at 12 V DC 80 mA max.
Measuring rate	0.5 kHz
Stability (temperature)	±50 x 10 ⁻⁶ /°C f.s. (typical)
Repeatability	1 LSB
Operating temperature	See specification of the respective sensor
Protection	Reverse polarity, short circuit
Dielectric strength	1 kV (V AC, 50 Hz, 1 min.)
EMC	EN 61326-1:2013

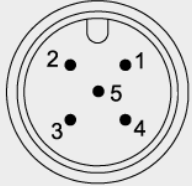
Signal wiring	Output signals	Connector pin no.
Connector M12, 5 pin  <p>View to the sensor connector</p>	Shield	1
	Excitation +	2
	GND	3
	CAN-H	4
	CAN-L	5

Accessories

Connector/bus cable M12, 5 pin CAN-Bus

The 5-lead shielded cable is supplied with a female 5 pin M12 connector at one end and a male 5 pin M12 connector at the other end.

Available lengths are 0.3 m, 2 m, 5 and 10 m.

Cable diameter: 6.7 ±0.2 mm

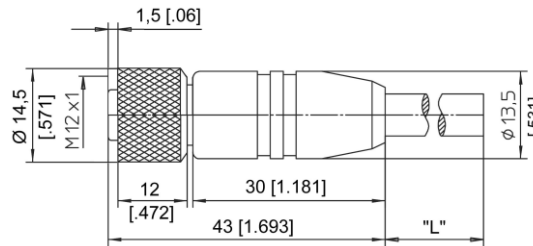

Order code

KAB - xM - M12/5F/G - M12/5M/G - CAN

IP69: **KAB - xM - M12/5F/G/69K - M12/5M/G/69K - CAN**

xM = length in m

T-connector for bus cable M12, 5 pin CAN-Bus

Order code

KAB - TCONN - M12/5M - 2M12/5F - CAN



Terminating resistor M12, 5 pin CAN-Bus

Order code

KAB - RTERM - M12/5M/G - CAN



Applicable for cable carriers

Maximum movement speed	3 m/s
Maximum acceleration	5 m/s ²
Minimum bending radius	10 x cable diameter

Tape pulley WBR1

Order code: WBR1

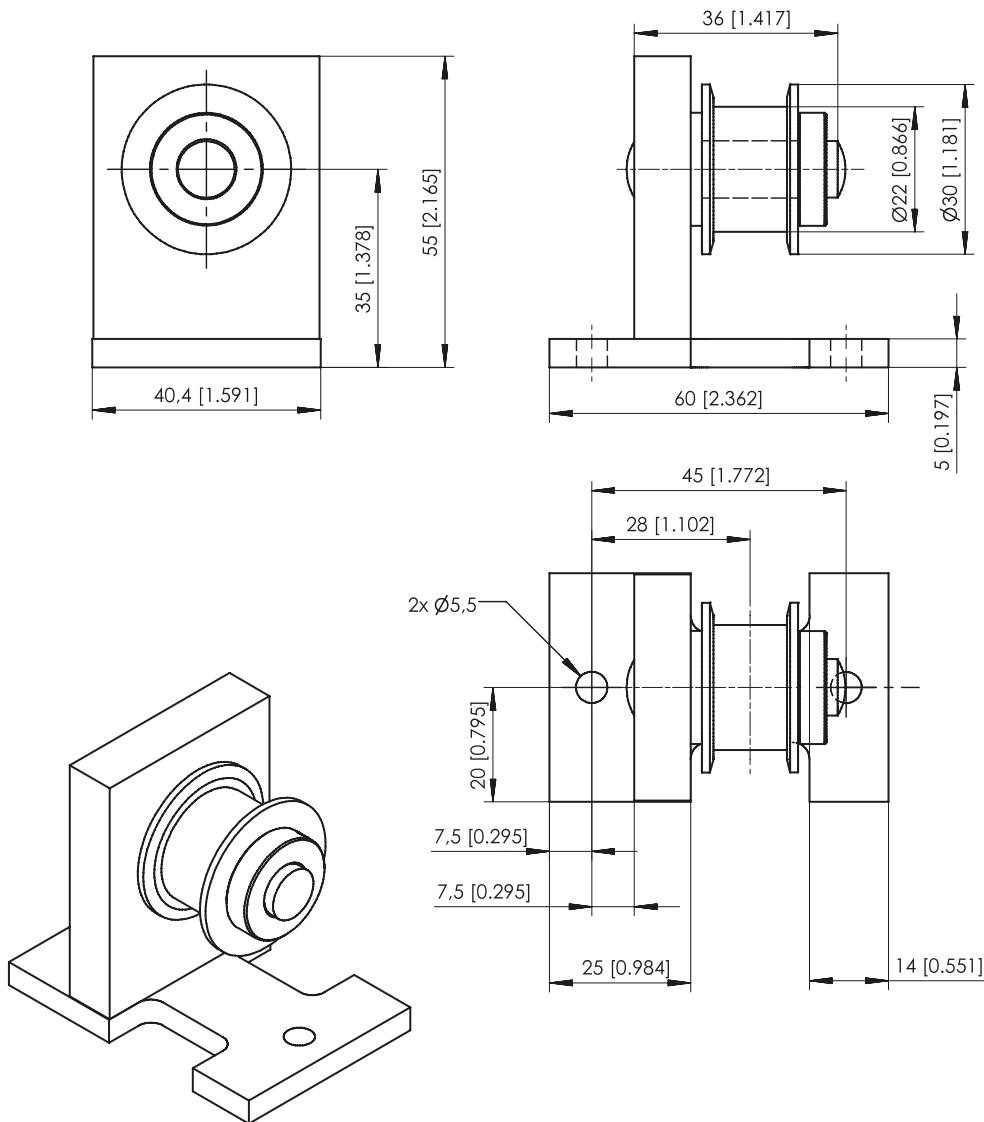

Dimensions in mm [inch]

Dimensions informative only.

For guaranteed dimensions consult factory.